



總寫字樓: 香港九龍塘尾道 60-62 號福康工業大廈 4 樓 402 室  
Head Office: Room 402, 4/F., Fuk Hong Industrial Building, 60-62 Tong Mi Road, Kowloon, Hong Kong

TEL: (852) 2393 1144 FAX: 2789 3030  
E-mail: sales@samhing.com.hk  
Website: www.samhing.com.hk  
旺角門市: 香港九龍荔枝角道 63 號地舖 (旺角維景酒店對面) G/F., 63 Lai Chi Kok Road, Kowloon, Hong Kong  
太子門市: 香港九龍界限街 13 號 F 地舖 G/F., 13F Boundary Street, Kowloon, Hong Kong  
TEL: (852) 2398 2283 FAX: 2398 3508  
TEL: (852) 2393 3729 FAX: 2332 9821  
TEL: (020) 8494 3831 FAX: 8494 4868

# H-AUS2 Series

## Electronic Crane Scale



Sample picture for reference only

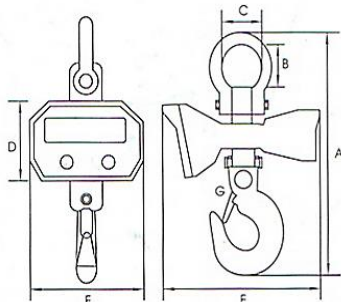

Accuracy class	GB/T 11883-2002 III
Safe over-load	150% F.S.
Damaging over-load	200% F.S.
Operation temp. range	-10 - 40°C
Relative humidity	<90% R.H.
Zero range	≤ 4% F.S.
Tare range	4% - 100% F.S.
Stabilization time	< 5 seconds

Capacity (T)	Readability (kg)	External Dimensions (mm)							Net Weight (kg)
		Length	Ring Radian	Ring Width	Chassis Height	Chassis Length	Width	Hook	
		A	B	C	D	E	F	G	
1	0.5	480	103	58	130	265	190	50	12
2	1	480	103	58	130	265	190	50	12
3	1	480	103	58	130	265	190	50	12
5	2	595	136	90	130	265	190	66	19
10	5	650	138	90	235	340	235	66	24

- 30mm digit height LED display.
- Over load indication.
- Power saving mode and automatic shutdown function.
- Built-in rechargeable battery. Charger included.
- Low battery voltage indication.
- Wireless remote control included. Control distance of 10 – 15m.
- Chrome plated shackle and hook included.

本公司另設政府認可實驗室 編號 148

三興製磅廠有限公司 – 測試及校正實驗室  
Sam Hing Scales Fty. Ltd. – Testing and Calibration Laboratory  
Laboratory email: lab@samhing.com.hk

Cat. H-001.E3